

TECHNICAL DESCRIPTION

SET-2010

32 differential / 64 single ended channel routing card

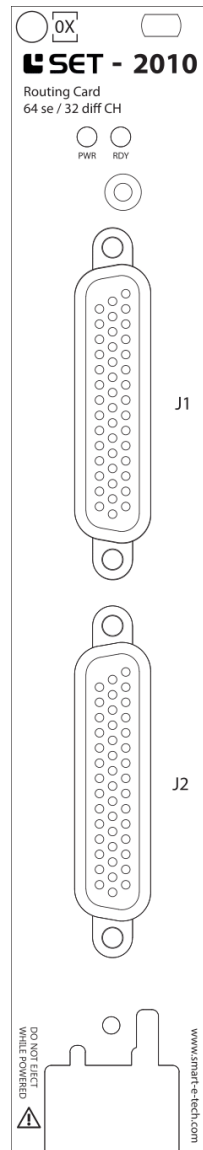

This document 9040TDD0320 is a technical description of the SET-2010.



Note Before you begin, complete the Software and Hardware installation procedures applicable to your application.



Note The guidelines in this document are specific to the SET-2010. The other components in the system might not meet the same safety ratings. Refer to the documentation of each component in the system to determine the safety and EMC ratings for the entire system.

MORE INFORMATION ON OUR WEBSITE:

www.smart-e-tech.de/slsc



Safety Guidelines



Caution Do not operate the SET-2010 in a manner not specified in this document. Product misuse can result in a hazard. You can compromise the safety protection built into the product if the product is damaged in any way. If the product is damaged, return it for repair.

Electromagnetic Compatibility Guidelines

This product was tested and complies with the regulatory requirements and limits for electromagnetic compatibility (EMC). These requirements and limits provide reasonable protection against harmful interference when the product is operated in the intended operational electromagnetic environment.

This product is intended for use in industrial locations. However, harmful interference may occur in some installations, when the product is connected to a peripheral device or test object, or if the product is used in residential or commercial areas. To minimize interference with radio and television reception and prevent unacceptable performance degradation, install, and use this product in strict accordance with the instructions in the product documentation.

Furthermore, any changes or modifications to the product not expressly approved by SET GmbH could void your authority to operate it under your local regulatory rules.



Caution To ensure the specified EMC performance, operate this product only with shielded cables and accessories.



Caution To ensure the specified EMC performance, the length of any cable attached to connectors J1 and J2 must be no longer than 3 m (10 ft).



Description

The SET-2010 Routing Card is a large-scale, high density switching matrix. With 64 single-ended or 32 differential channels. The SET-2010 provides exceptional signal routing capabilities in a small form factor. Unlike traditional routing matrix cards, the SET-2010 is designed specifically for the challenges of signal routing in HIL systems. To maximize customizability, the SET-2010 features two plug-in module slots that can provide features such as line fault insertion and instrument connect. The base card provides multiplexer functions for both front-panel IO and rear connectivity. Additionally, the SET-2010 Routing Card comes with a high current fault injection bus.

Circuitry

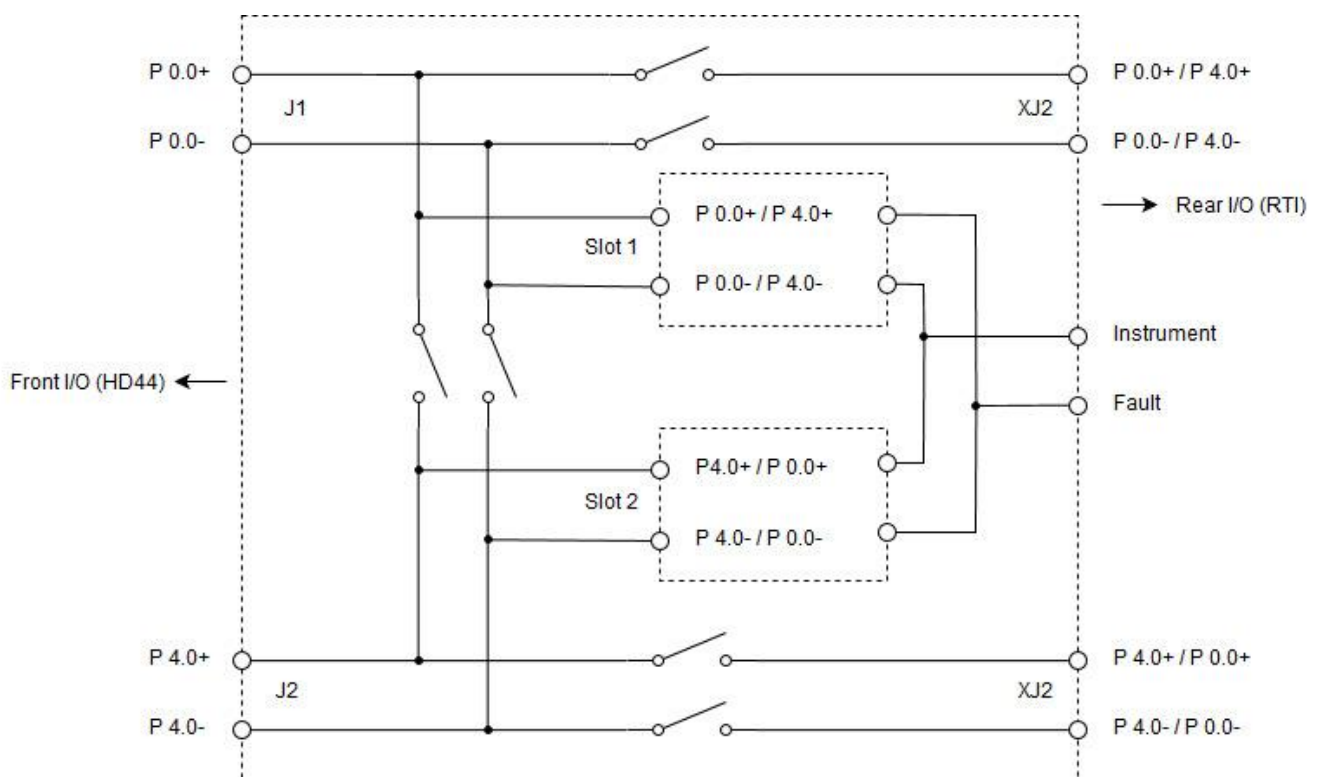

Note The diagram only shows one channel for each connector J1/J2.

P0.x – P3.x
P4.x – P7.x

are connected with Slot 1 P0.x – P3.x
are connected with Slot 2 P0.x – P3.x

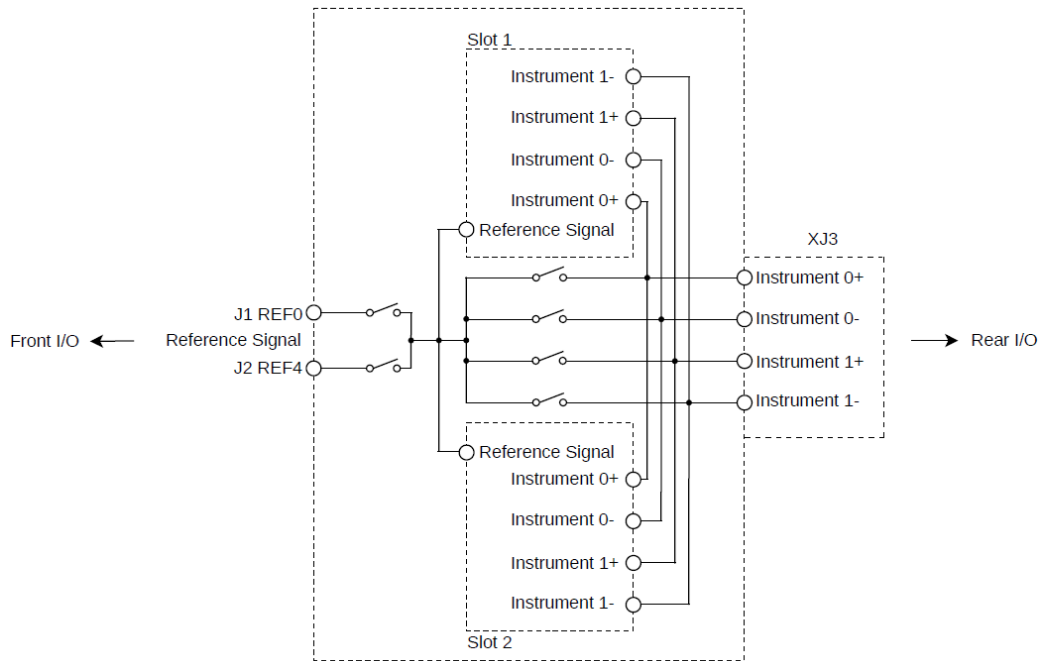

Reference routing to the instrument bus

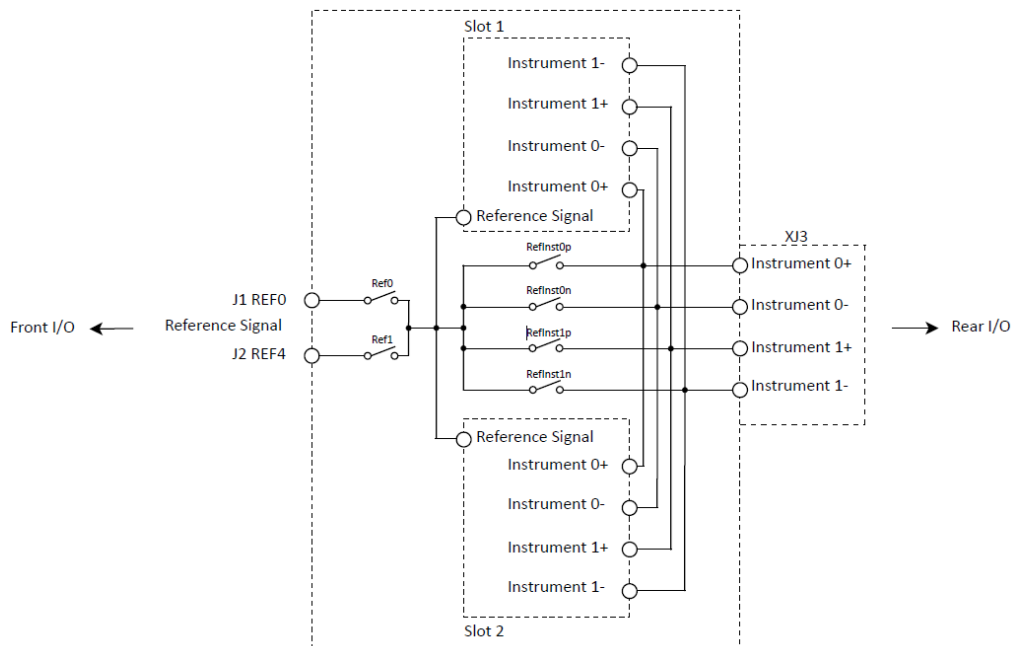

Reference routing to the fault bus



Note There is one common reference signal on the Routing Card which can be switched on instrument and fault bus as well as on one reference (REF0/REF4) of each front connector.

Signal REF_x/EN_x: 0, 1, 2 & 3 are connected with Slot 1.

Signal REF_x/EN_x: 4, 5, 6 & 7 are connected with Slot 2.

All voltages are relative to GND unless otherwise noted.

J1, J2 Pinout (Front)

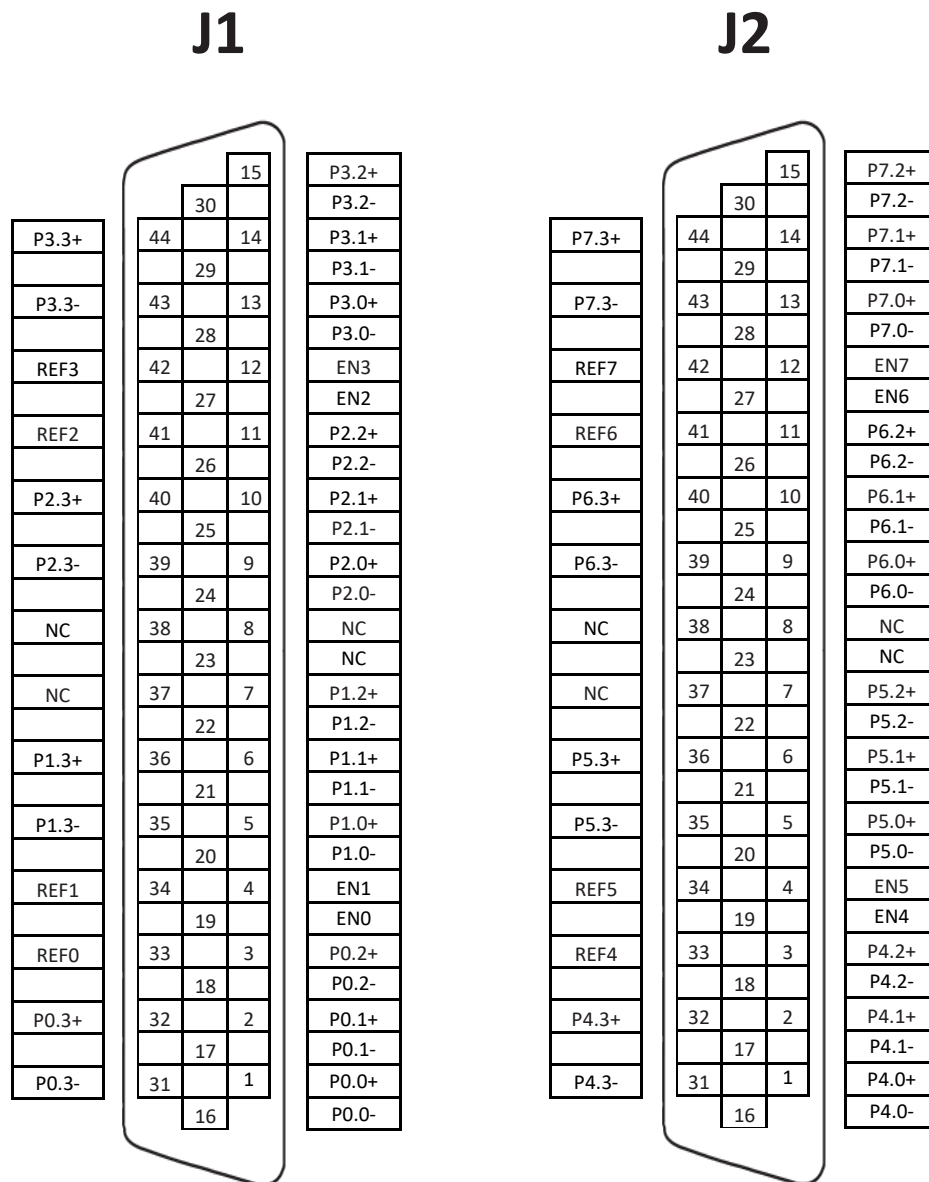

Signal	Description
Px.y	Line y in Port x
DGND	Ground connection
NC	No connection
EN	Enable
REF	Reference

J1, J2 Connector Pin Assignments

XJ2 Connector Pinout (Rear)

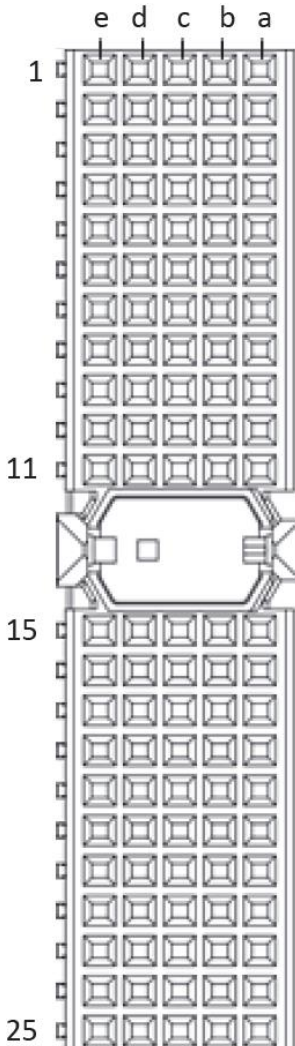

Row	e	d	c	b	a
1	P0.0- / P4.0-	P0.0+ / P4.0+	NC	P0.1- / P4.1-	P0.1+ / P4.1+
2	P0.2- / P4.2-	P0.2+ / P4.2+	NC	P0.3- / P4.3-	P0.3+ / P4.3+
3	GND	GND	GND	GND	GND
4	P1.0- / P5.0-	P1.0+ / P5.0+	NC	P1.1- / P5.1-	P1.1+ / P5.1+
5	P1.2- / P5.2-	P1.2+ / P5.2+	NC	P1.3- / P5.3-	P1.3+ / P5.3+
6	GND	GND	GND	GND	GND
7	P2.0- / P6.0-	P2.0+ / P6.0+	NC	P2.1- / P6.1-	P2.1+ / P6.1+
8	P2.2- / P6.2-	P2.2+ / P6.2+	NC	P2.3- / P6.3-	P2.3+ / P6.3+
9	DGND	DGND	DGND	DGND	DGND
10	P3.0- / P7.0-	P3.0+ / P7.0+	NC	P3.1- / P7.1-	P3.1+ / P7.1+
11	P3.2- / P7.2-	P3.2+ / P7.2+	NC	P3.3- / P7.3-	P3.3+ / P7.3+
12	NC	NC	NC	NC	NC
13	NC	NC	NC	NC	NC
14	NC	NC	NC	NC	NC
15	P4.0- / P0.0-	P4.0+ / P0.0+	NC	P4.1- / P0.1-	P4.1+ / P0.1+
16	P4.2- / P0.2-	P4.2+ / P0.2+	NC	P4.3- / P0.3-	P4.3+ / P0.3+
17	GND	GND	GND	GND	GND
18	P5.0- / P1.0-	P5.0+ / P1.0+	NC	P5.1- / P1.1-	P5.1+ / P1.1+
19	P5.2- / P1.2-	P5.2+ / P1.2+	NC	P5.3- / P1.3-	P5.3+ / P1.3+
20	DGND	DGND	DGND	DGND	DGND
21	P6.0- / P2.0-	P6.0+ / P2.0+	NC	P6.1- / P2.1-	P6.1+ / P2.1+
22	P6.2- / P2.2-	P6.2+ / P2.2+	NC	P6.3- / P2.3-	P6.3+ / P2.3+
23	GND	GND	GND	GND	GND
24	P7.0- / P3.0-	P7.0+ / P3.0+	NC	P7.1- / P3.1-	P7.1+ / P3.1+
25	P7.2- / P3.2-	P7.2+ / P3.2+	NC	P7.3- / P3.3-	P7.3+ / P3.3+

XJ2 Connector Pin Assignments

Signal	Description
Px.y	Line y in Port x
GND	Ground connection
NC	No connection

XJ2 Connector Signal Descriptions

XJ3 Connector Pinout (Rear)

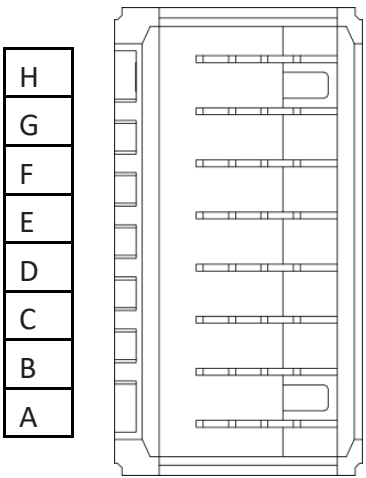

Pins	Signal	Slot1/Slot2
H	V1+	Instrument_0+
G	V1-	Instrument_0-
F	V2+	Instrument_1+
E	V2-	Instrument_1-
D	V3+	Fault_A
C	V3-	Fault_B
B	V4+	Fault_C
A	V4-	Fault_D

XJ3 Connector Pin Assignments

LED Behavior

LED Name	LED Behavior	Definition of Behavior
PWR	Off	No power on board.
	Solid green	Power good state.
RDY	Off	Module card is unpowered or reset active.
	Solid green	Card is recognized by chassis and ready to communicate
	Amber	Chassis is communicating.

Error Handling

LED Name	LED Behavior	Actions
PWR	Off	<ul style="list-style-type: none"> - Check chassis power supply. - Check external power supply if used.
RDY	Off	<ul style="list-style-type: none"> - Check plugin module on board. - Check fuse on board.

Hardware Specifications

Absolute Maximum Ratings			
Property	Condition	Value	Comment
Max. Input Voltage	Any Pin	60 Vdc	
Min. Input Voltage	Any Pin	-60 Vdc	
Max. Switching Power	DC, Resistive load	60 W	
Max. Current rating		1.5 A	

Technical Data			
Property	Condition	Value	Comment
Update Time		10 ms	SLSC Commit CMD duration
Max. Initial contact Resistance	J1 -> XJ2 J2 -> XJ2 J1 -> J2	500 mΩ	
Max. Electrical Lifetime Expected	1 A, 30 Vdc resistive	Min 10 ⁵ operations	
Min. Electrical Lifetime Expected	1.5 A, 30 Vdc resistive	Min 10 ⁴ operations	
Bandwidth	-3 dB, 50 Ω Termination	≤ 20 MHz	

Physicals Characteristics			
Property	Condition	Value	Comment
Module Dimensions	Excluding ejector	144.32 mm x 30.48 mm x 302 mm (H x W x D)	Standard SLSC card size
Front Panel Connector		2x female DB -44 high-density D-Sub with 4-40 UNC screw lock	For mating connectors and cables, see below
RTI Connector		2 mm hard metric per IEC 61076-101	Any RTI marked

Environmental			
Property	Condition	Value	Comment
Operating Humidity	Relative, non-condensing	10%-90%	
Storage Humidity	Relative, non-condensing	5%-95%	
Operating temperature	Forced-air cooling from chassis	0°C - 40°C	
Storage Temperature		-40°C - 85°C	
Maximum Altitude		2000 m	