

TECHNICAL DESCRIPTION

SET-1250

32 Channel 4-20 mA Current Sink Card

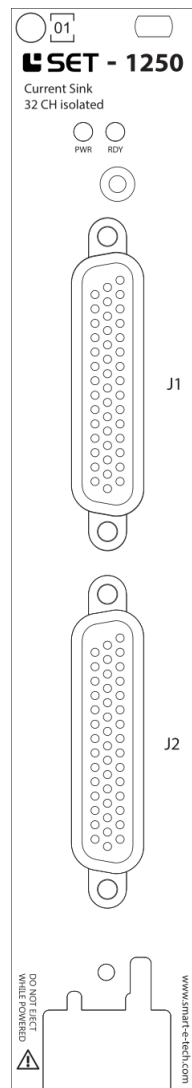

This document 9040TDD1200-01 is a technical description of the SET-1250.



Note Before you begin, complete the Software and Hardware installation procedures applicable to your application.



Note The guidelines in this document are specific to the SET-1250. The other components in the system might not meet the same safety ratings. Refer to the documentation of each component in the system to determine the safety and EMC ratings for the entire system.

MORE INFORMATION ON OUR WEBSITE:

www.smart-e-tech.de/slsc



Safety Guidelines



Caution Do not operate the SET-1250 in a manner not specified in this document. Product misuse can result in a hazard. You can compromise the safety protection built into the product if the product is damaged in any way. If the product is damaged, return it for repair.

Electromagnetic Compatibility Guidelines

This product was tested and complies with the regulatory requirements and limits for electromagnetic compatibility (EMC). These requirements and limits provide reasonable protection against harmful interference when the product is operated in the intended operational electromagnetic environment.

This product is intended for use in industrial locations. However, harmful interference may occur in some installations, when the product is connected to a peripheral device or test object, or if the product is used in residential or commercial areas. To minimize interference with radio and television reception and prevent unacceptable performance degradation, install and use this product in strict accordance with the instructions in the product documentation.

Furthermore, any changes or modifications to the product not expressly approved by SET GmbH could void your authority to operate it under your local regulatory rules.



Caution To ensure the specified EMC performance, operate this product only with shielded cables and accessories.



Caution To ensure the specified EMC performance, the length of any cable attached to connectors J1 and J2 must be no longer than 3 m (10 ft).

Description

The SET-1250 a-20 mA Current Sink Card provides current sink simulation for 32 isolated channels and supports an extended range of 0-24.6 mA.

Each channel provides a disconnection relay and a short circuit MOSFET, by which open and short circuit faults can be simulated. The short circuit MOSFET has an overcurrent protection with an integrated current limitation.

The desired simulation value and fault insertion can be set for each channel independently. The SET-1250 provides both RTI API and SLSC API for configuring the outputs.

Circuitry

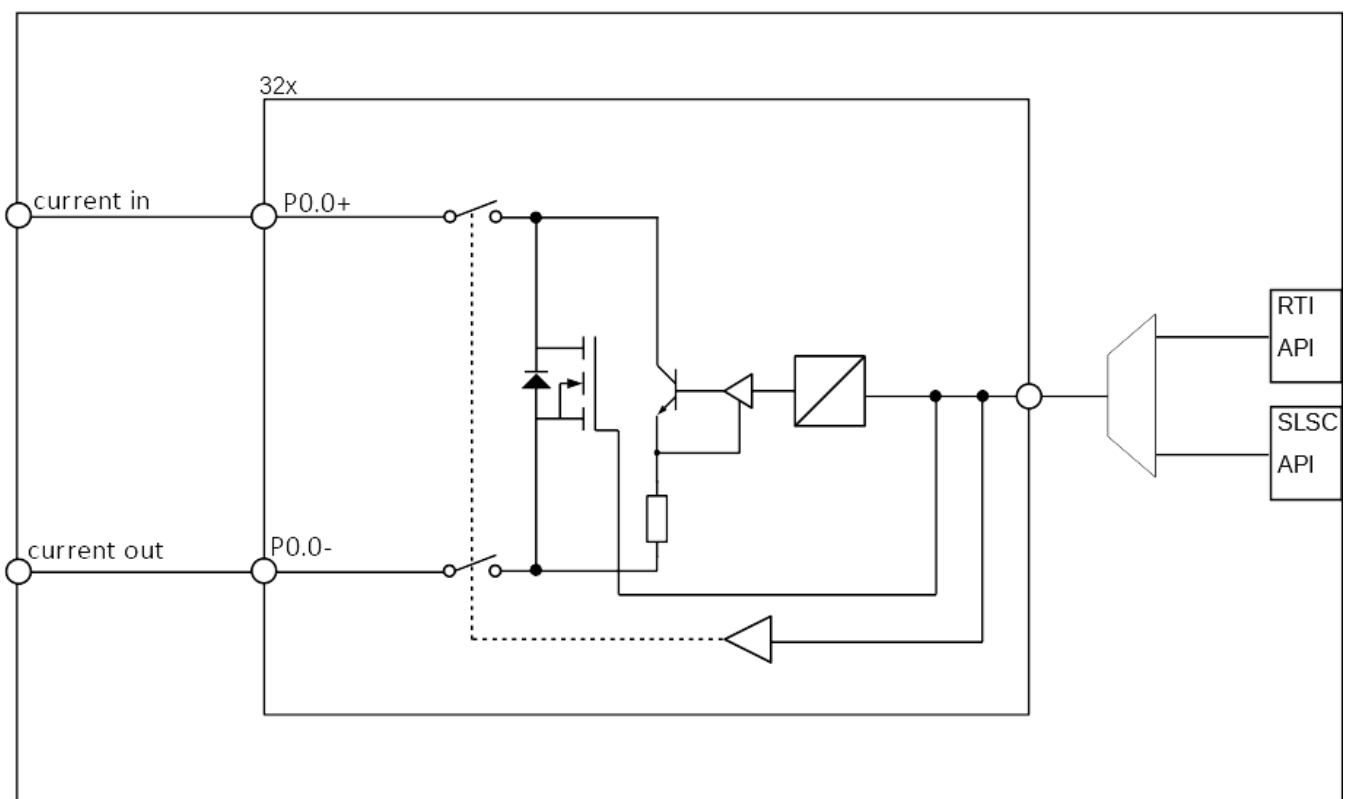

Note Diagram only shows one channel per front connector J1/J2.

J1, J2 Pinout (Front)

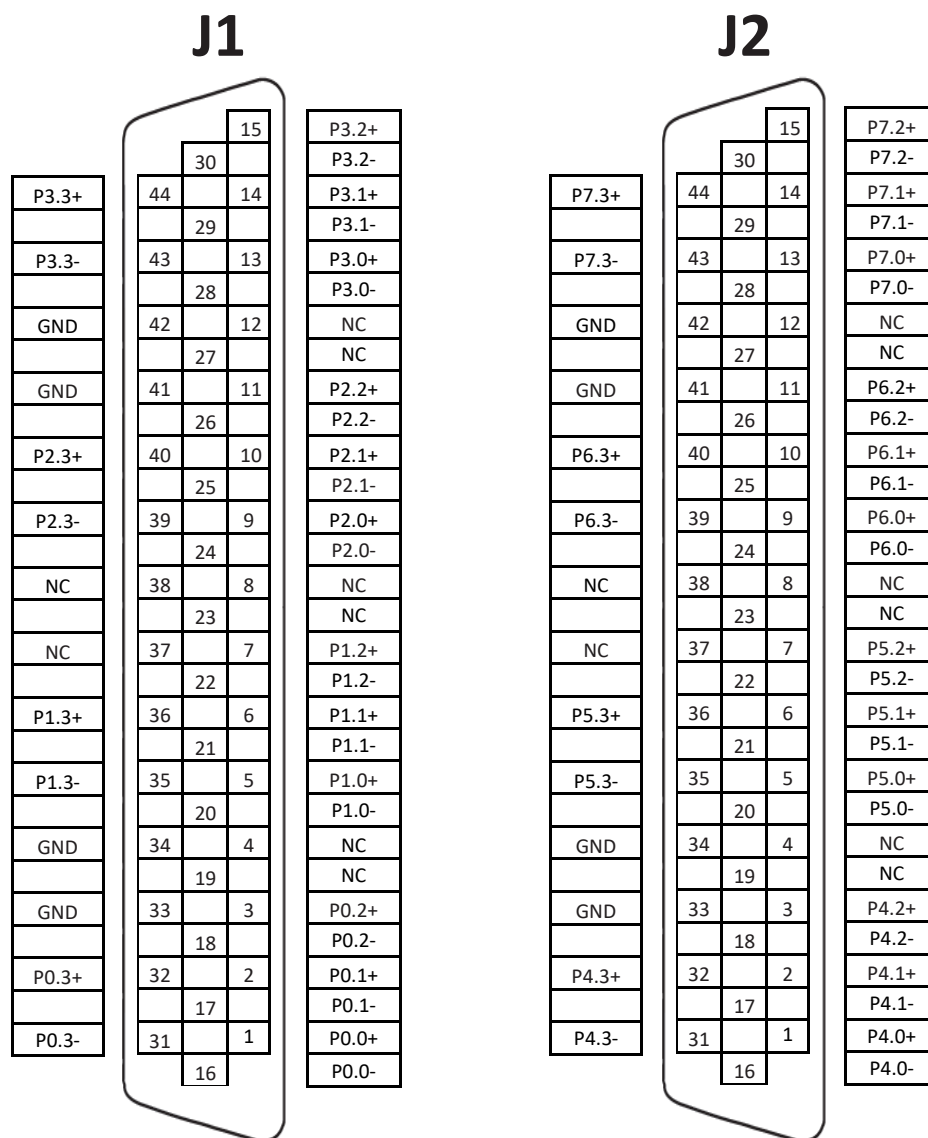

Signal	Description
Px.y	Line y in Port x
NC	No connection
GND	Ground connection

J1, J2 Connector Pin Assignments

XJ2 Connector Pinout (Rear)

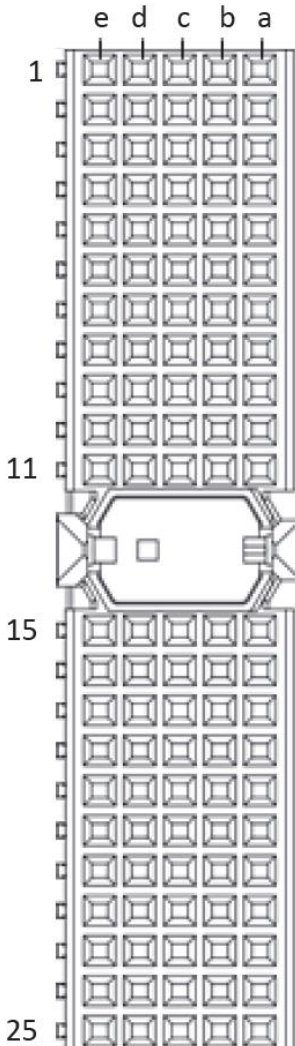

Row	e	d	c	b	a
1	DIO_1.3	DIO_1.2	NC	DIO_1.1	DIO_1.0
2	DIO_1.7	DIO_1.6	NC	DIO_1.5	DIO_1.4
3	GND	GND	GND	GND	GND
4	DIO_2.3	DIO_2.2	NC	DIO_2.1	DIO_2.0
5	DIO_2.7	DIO_2.6	NC	DIO_2.5	DIO_2.4
6	GND	GND	GND	GND	GND
7	DIO_3.3	DIO_3.2	NC	DIO_3.1	DIO_3.0
8	DIO_3.7	DIO_3.6	NC	DIO_3.5	DIO_3.4
9	GND	GND	GND	GND	GND
10	DIO_4.3	DIO_4.2	NC	DIO_4.1	DIO_4.0
11	DIO_4.7	DIO_4.6	NC	DIO_4.5	DIO_4.4
12	NC	NC	NC	NC	NC
13	NC	NC	NC	NC	NC
14	NC	NC	NC	NC	NC
15	NC	NC	NC	NC	NC
16	NC	NC	NC	NC	NC
17	GND	GND	GND	GND	GND
18	NC	NC	NC	NC	NC
19	NC	NC	NC	NC	NC
20	GND	GND	GND	GND	GND
21	NC	NC	NC	NC	NC
22	NC	NC	NC	NC	NC
23	GND	GND	GND	GND	GND
24	NC	NC	NC	NC	NC
25	NC	NC	NC	NC	NC

XJ2 Connector Pin Assignments

Signal	Description
DIO_x.y	Digital IO signal for transferring required sink current value.
GND	Ground connection
NC	No connection

XJ2 Connector Signal Descriptions

LED Behavior

LED Name	LED Behavior	Definition of Behavior
PWR	Off	No power present on the board
	Solid green	Power good state
RDY	Off	Module card is unpowered or reset active
	Solid green	Card is recognized by chassis and ready to communicate
	Amber	Chassis is communicating

Error Handling

LED Name	LED Behavior	Actions
PWR	Off	<ul style="list-style-type: none"> - Check power supply of chassis - Check external power supply if used
PWR	Blinking Red	<ul style="list-style-type: none"> - Check plugin module on board - Check fuse on board

Hardware Specifications

Absolute Maximum Ratings			
Property	Condition	Value	Comment
Max. Input Voltage	Any Front Pin to GND (Except the GND pins)	60 V _{DC}	
Min. Input Voltage		-60 V _{DC}	
Max. Differential Input Voltage	Max. voltage between positive and negative signal pin of a channel	+30 V _{DC}	Higher voltage might cause damage.
Min. Differential Input Voltage	Min. voltage between positive and negative signal pin of a channel needed for 24.6mA	+3.2 V _{DC}	Lower voltages will lead to a lower current limit.
		0 V _{DC}	Negative voltages might cause damage.
Max. Input Current when Short Circuit MOSFET is active		200 mA	Higher currents might cause damage

Technical Data			
Property	Condition	Value	Comment
Max. Current Sink Value		24.6 mA	
Min. Input Current when Short Circuit MOSFET is active	Differential Input Voltage >2 V	160 mA	
Expected Electrical Lifetime	1 A, 30 Vdc resistive	Min 10 ⁵ operations	
Min. Resistance in normal operation		100 Ω ±1%	
Resistance of Short Circuit MOSFET	@200 mA	< 2 Ω	
Gain Error		+1%/-2.6%	
Offset Error		±0.09 mA	

Physicals Characteristics			
Property	Condition	Value	Comment
Module Dimensions	Excluding ejector	144.32 mm x 30.48 mm x 302 mm (H x W x D)	Standard SLSC card size
Front Panel Connector		2x female DB -44 high-density D-Sub with 4-40 UNC screw lock	For mating connectors and cables, see below
RTI Connector		2mm hard metric per IEC 61076-101	Any RTI marked

Environmental			
Property	Condition	Value	Comment
Operating Humidity	Relative, non-condensing	10%-90%	
Storage Humidity	Relative, non-condensing	5%-95%	
Operating Temperature	Forced-air cooling from chassis	0°C to +40°C	
Storage Temperature		-40°C to +85°C	
Maximum Altitude		2000m	