

TECHNICAL DESCRIPTION

SET-1320

32 Channel Isolated Digital Output Card

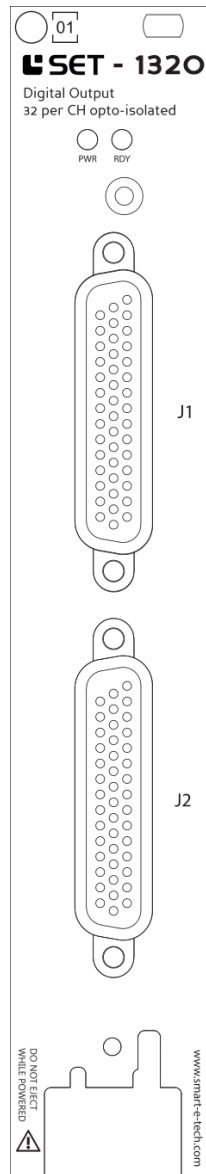

This document 9040TDD1020 is a technical description of the SET-1320.



Note Before you begin, complete the software and hardware installation procedures applicable to your application.



Note The guidelines in this document are specific to the SET-1320. The other components in the system might not meet the same safety ratings. Refer to the documentation of each component in the system to determine the safety and EMC ratings for the entire system.

MORE INFORMATION ON OUR WEBSITE:

www.smart-e-tech.de/slsc

Isolation Guidelines



Caution Do not operate the SET-1320 in a manner not specified in this document. Product misuse can result in a hazard. You can compromise the safety protection built into the product if the product is damaged in any way. If the product is damaged, return it for repair.



Note The isolation of the front panel connectors is intended to prevent ground loops and does not meet UL or IEC ratings for safety isolation.

Electromagnetic Compatibility Guidelines

This product was tested and complies with the regulatory requirements and limits for electromagnetic compatibility (EMC). These requirements and limits provide reasonable protection against harmful interference when the product is operated in the intended operational electromagnetic environment.

This product is intended for use in industrial locations. However, harmful interference may occur in some installations, when the product is connected to a peripheral device or test object, or if the product is used in residential or commercial areas. To minimize interference with radio and television reception and prevent unacceptable performance degradation, install, and use this product in strict accordance with the instructions in the product documentation.

Furthermore, any changes or modifications to the product not expressly approved by SET GmbH could void your authority to operate it under your local regulatory rules.



Caution To ensure the specified EMC performance, operate this product only with shielded cables and accessories.



Caution To ensure the specified EMC performance, the length of any cable attached to connectors J1 and J2 must be no longer than 3 m (10 ft.)

Description

The SET-1320 device is an isolated digital output interface for NI-SLSC. This card provides 32 optically isolated open-collector outputs that can switch up to 100 mA at 60 V. SET-1320 combines high-density IO with high isolation voltages and a wide output voltage range. It allows you to break ground loops and protect susceptible test equipment from DUTs. It also enables you to interface standard logic-level test equipment with almost any system voltage. The SET-1320 can be driven through the RTI or through the SLSC chassis via software. RTI inputs are compatible with LVCMOS, LVTTTL and TTL logic levels.

The SET-1320 has 32 optically isolated open-collector outputs. Current can flow from CH+ to CH- when the output is on. The outputs are reverse polarity protected to -60 V DC. The outputs are controlled from a logic-level digital output source, like NI R-Series FPGA or NI C-Series digital output modules, through the RTI.

Circuitry

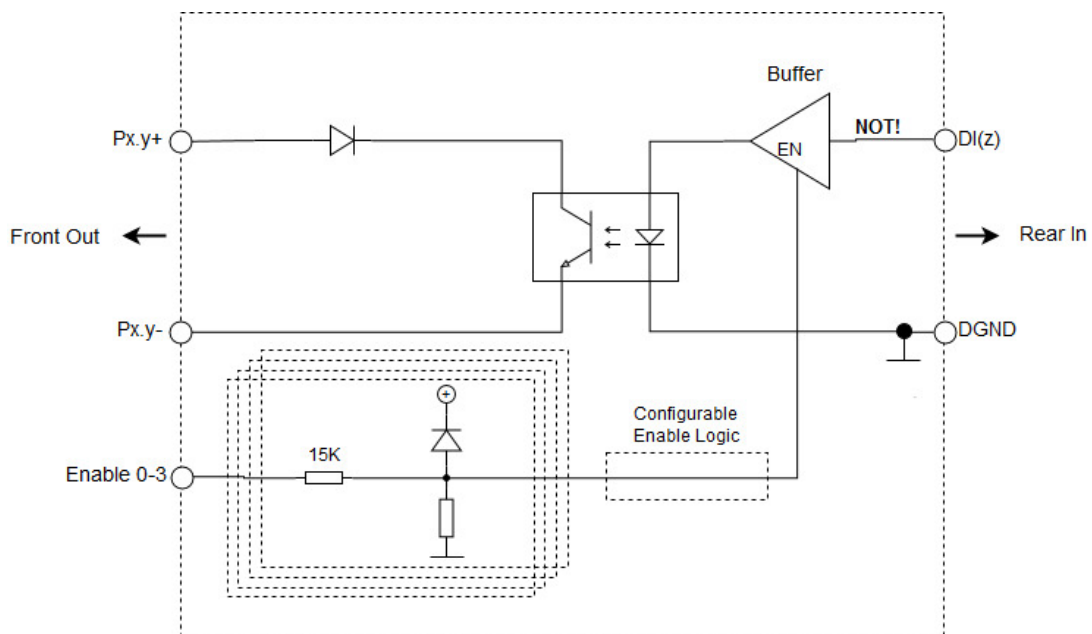

 **Note** Diagram only shows one channel.

All voltages are relative to DGND unless otherwise noted.

 **Note** The power up default configuration of the Enable Logic is Channel 0 to 15 enabled by EN0; Channel 16 to 31 enabled by EN2.

J1, J2 Pinout (Front)

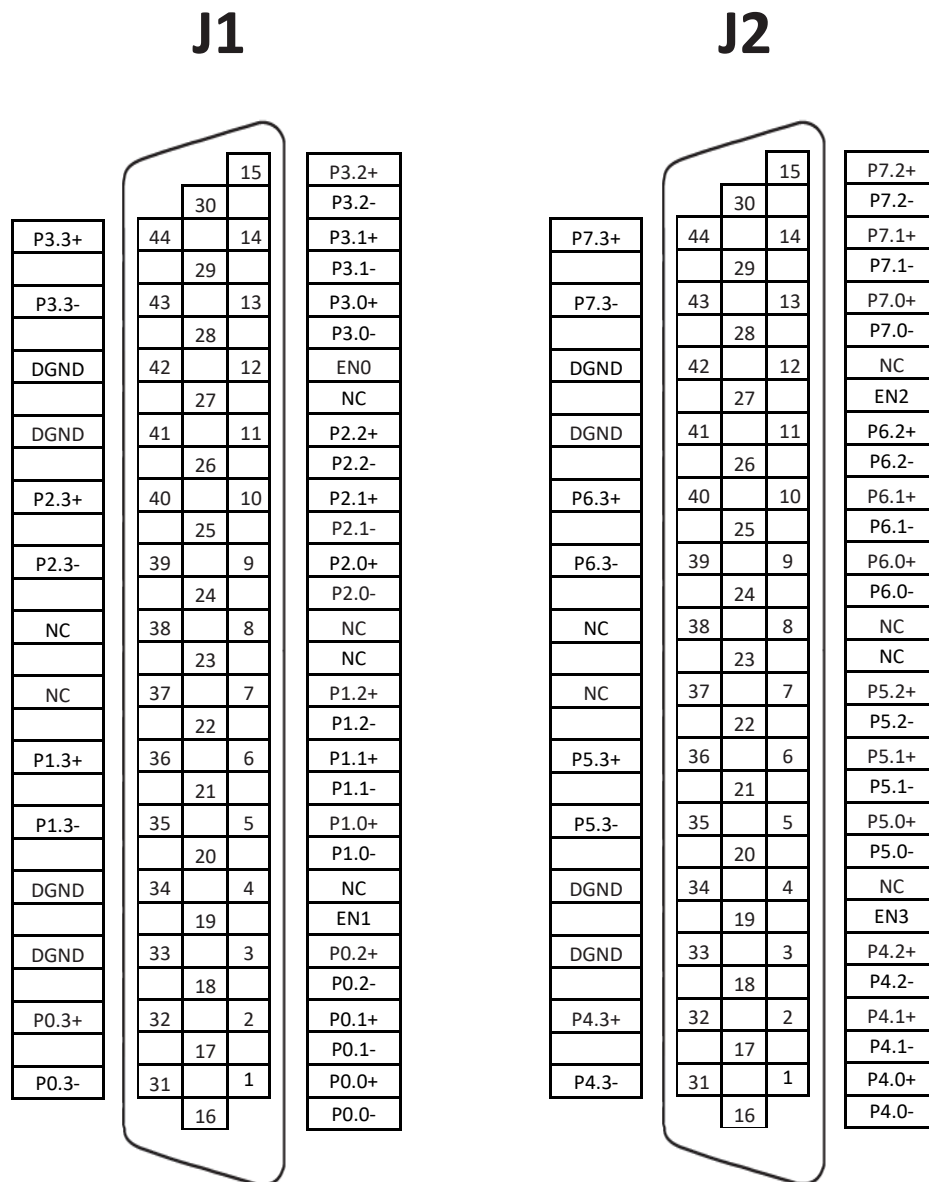

Signal	Description
Px.y	Line y in Port x
DGND	Ground connection
NC	Not connected
EN	Enable

J1, J2 Connector Pin Assignments

J1		XJ2		J2		XJ2	
P0.0 +		DI0		P4.0 +		DI16	
P0.0 -				P4.0 -			
P0.1+		DI1		P4.1+		DI17	
P0.1 -				P4.1 -			
P0.2 +		DI2		P4.2 +		DI18	
P0.2 -				P4.2 -			
P0.3 +		DI3		P4.3 +		DI19	
P0.3 -				P4.3 -			
P1.0 +		DI4		P5.0 +		DI20	
P1.0 -				P5.0 -			
P1.1 +		DI5		P5.1 +		DI21	
P1.1 -				P5.1 -			
P1.2 +		DI6		P5.2 +		DI22	
P1.2 -				P5.2 -			
P1.3 +		DI7		P5.3 +		DI23	
P1.3 -				P5.3 -			
P2.0 +		DI8		P6.0 +		DI24	
P2.0 -				P6.0 -			
P2.1 +		DI9		P6.1 +		DI25	
P2.1 -				P6.1 -			
P2.2 +		DI10		P6.2 +		DI26	
P2.2 -				P6.2 -			
P2.3 +		DI11		P6.3 +		DI27	
P2.3 -				P6.3 -			
P3.0 +		DI12		P7.0 +		DI28	
P3.0 -				P7.0 -			
P3.1 +		DI13		P7.1 +		DI29	
P 3.1-				P 7.1-			
P3.2+		DI14		P7.2+		DI30	
P3.2-				P7.2-			
P3.3+		DI15		P7.3+		DI31	
P3.3-				P7.3-			

Signal Assignments



XJ2 Connector Pinout (Rear)

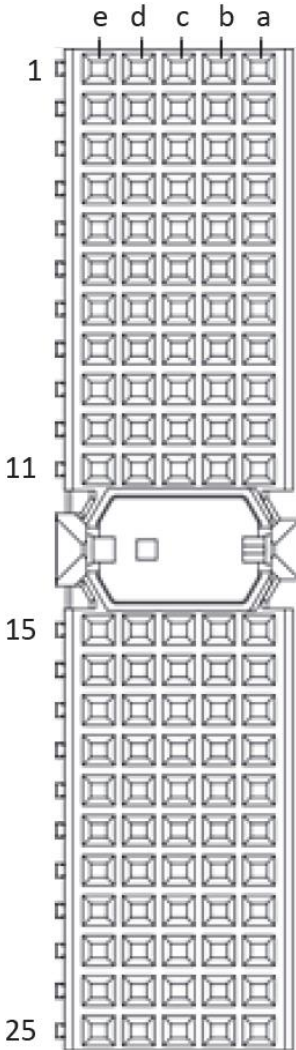

Row	e	d	c	b	a
1	DI 3	DI 2	NC	DI 1	DI 0
2	DI 7	DI 6	NC	DI 5	DI 4
3	DGND	DGND	DGND	DGND	DGND
4	DI 11	DI 10	NC	DI 9	DI 8
5	DI 15	DI 14	NC	DI 13	DI 12
6	DGND	DGND	DGND	DGND	DGND
7	DI 19	DI 18	NC	DI 17	DI 16
8	DI 23	DI 22	NC	DI 21	DI 20
9	DGND	DGND	DGND	DGND	DGND
10	DI 27	DI 26	NC	DI 25	DI 24
11	DI 31	DI 30	NC	DI 29	DI 28
15	NC	NC	NC	NC	NC
16	NC	NC	NC	NC	NC
17	DGND	DGND	DGND	DGND	DGND
18	NC	NC	NC	NC	NC
19	NC	NC	NC	NC	NC
20	DGND	DGND	DGND	DGND	DGND
21	NC	NC	NC	NC	NC
22	NC	NC	NC	NC	NC
23	DGND	DGND	DGND	DGND	DGND
24	NC	NC	NC	NC	NC
25	NC	NC	NC	NC	NC

XJ2 Connector Pin Assignments

Signal	Description
DI	Digital input signal connection
GND	Ground connection
NC	No connection

XJ2 Connector Signal Descriptions

LED Behavior

LED Name	LED Behavior	Definition of Behavior
PWR	Off	No power present on the board
	Solid green	Power good state
RDY	Off	Module card is unpowered
	Solid green	Card is recognized by the chassis and ready to communicate
	Blinking amber	Chassis is communicating with the module card

Error Handling

LED Name	LED Behavior	Actions
Power	Off	<ul style="list-style-type: none"> - Checking the power supply of the chassis - Checking the external power supply if used
RDY	Off	<ul style="list-style-type: none"> - Checking the power supply of the chassis - Checking the external power supply if used

Hardware Specifications

Absolute Maximum Ratings			
Property	Condition	Value	Comment
Max. Output Channel Voltage	Measured between CH+ and CH-	60 V DC	
Max. Channel Reverse Voltage	Measured between Ch+ and Ch-	-60 V DC	
Channel to Channel		120 V DC	If pins are not adjacent to each other. Otherwise, 60 V DC.
Channel to Chassis		60 V DC	

Technical Data Front Interface			
Property	Condition	Value	Comment
Max. Output Switching Frequency	1 k Ω Pull up @ 5 V DC	50 kHz	Depending on Pull up Current
Max. Current		100 mA	Peak: 500 mA
Max. Output Forward Voltage	I = 100 mA	< 1.3 V DC	

Technical Data Rear Interface			
Property	Condition	Value	Comment
Max. Input Channel Voltage	Relative to DGND	5.5 V DC	

Physicals Characteristics			
Property	Condition	Value	Comment
Module Dimensions	Excluding ejector	144.32 mm x 30.48 mm x 302 mm (H x W x D)	Standard SLSC card size
Front Panel Connector		2x female DB -44 high-density D-Sub with 4-40 UNC screw lock	For mating connectors and cables, see below
RTI Connector		2 mm hard metric per IEC 61076-101	Any RTI marked

Environmental			
Property	Condition	Value	Comment
Operating Humidity	Relative, non-condensing	10%-90%	
Storage Humidity	Relative, non-condensing	5%-95%	
Module Operating Temperature	Forced-air cooling from chassis	0°C to 75°C	
Storage temperature		-40°C to 100°C	
Maximum altitude		2000 m	